

Information Sharing in Croydon

Sharing information in the interests of children and families is an essential element of both early intervention and safeguarding

Information sharing and data protection is the responsibility of everyone who works with children and families in Croydon. A common factor in inquiries into a child's death/serious injury is often that key information was not shared.

All Croydon practitioners should understand how to share information legally and professionally¹. Understanding how to share information safely and securely provides support for practitioners and helps build their confidence in making decisions about those they are working with.

Free elearning training in Information Sharing and Data Protections is available to anyone who lives or works in Croydon. To register or for further information contact: integrated.working@croydon.gov.uk

¹ All practitioners should be familiar with the cross government Information Sharing Guidance for practitioners and managers and any local Information Sharing Protocols. Practitioners should refer to their own organisation's information governance policies and procedures.

Seven golden rules for information sharing

- 1. Remember that the data Protection Act is not a barrier to sharing information** but provides a framework to ensure that personal information about living people is shared appropriately.
- 2. Be Open and honest** with the person (and/or their family where appropriate) from the outset about why, what, how and with whom information will be shared, and seek their agreement, unless it is unsafe or inappropriate to do so.
- 3. Seek advice** if you are in any doubt, without disclosing the identity of the person if possible.
- 4. Share with consent where appropriate** and, where possible, respect the wishes of those who do not consent to share confidential information. You may still share information without consent if, in your judgement, that lack of consent can be overridden in the public interest. You will need to base your judgement on the facts of the case.
- 5. Consider safety and well-being:** Base your information sharing decisions on considerations of the safety and well-being of the person and others who may be affected by their actions.
- 6. Necessary, proportionate, relevant, accurate, timely and secure:** Ensure that the information you share is necessary for the purpose for which you are sharing it, is shared only with those people who need to have it, is accurate and up-to-date, is shared in a timely fashion, and is shared securely.
- 7. Keep a record of your decision and the reasons for it – whether it is to share information or not. If you decide to share, then record what you have shared, with whom and for what purpose.**

Extract from the cross Government *Information Sharing: Guidance for practitioners and managers*.



Croydon Health and Wellbeing Board

A quick guide to information sharing in Croydon

Excellent Outcomes for Children, Young People and Families



Croydon Health
and Wellbeing
Board

Flowchart of key questions for information sharing

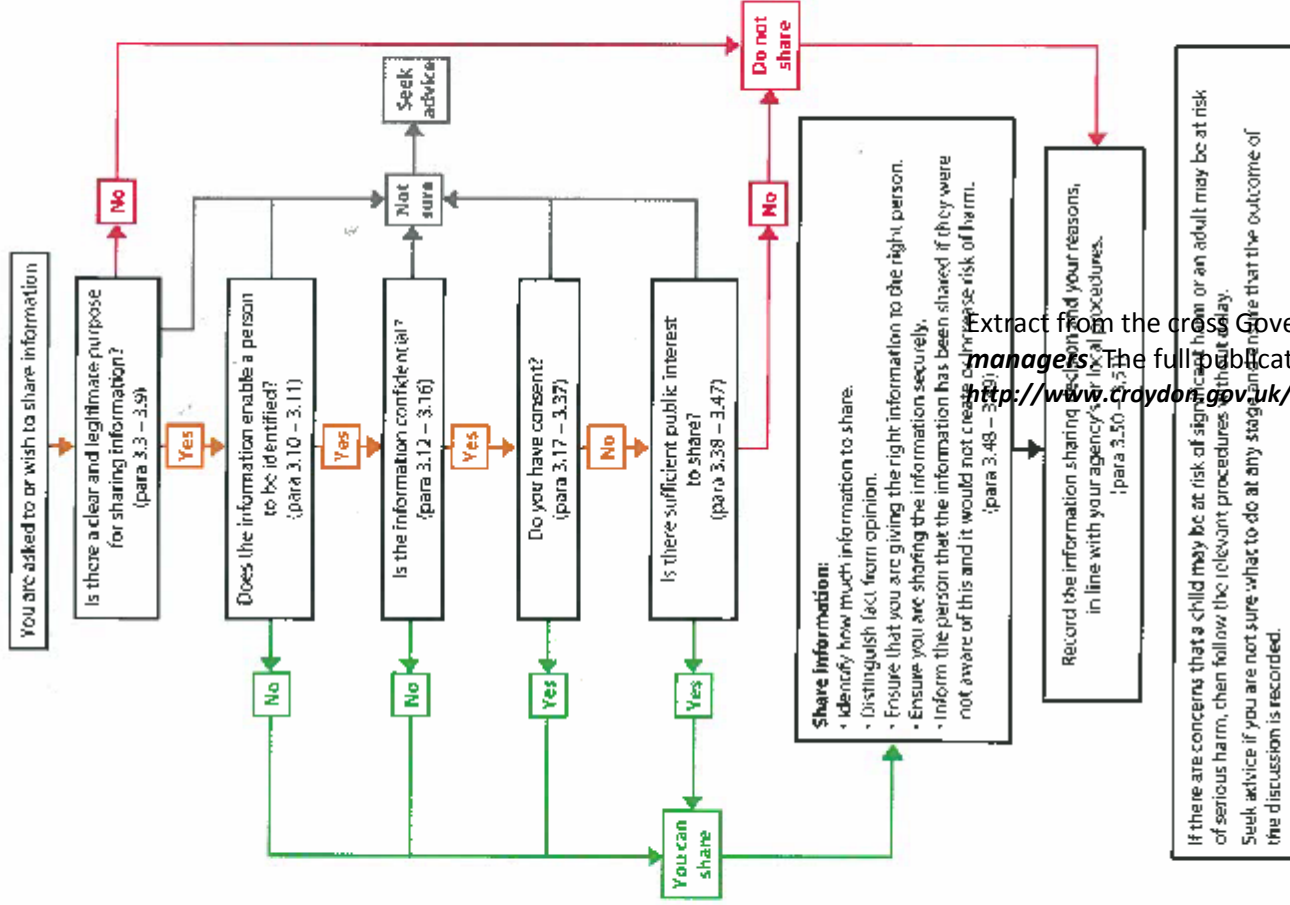

Extract from the cross-Government **Information Sharing: Guidance for practitioners and managers**. The full publication is available at <http://www.croydon.gov.uk/contents/departments/healthsocial/pdf/ccfp-guidance>